

Filter/Separator Cartridges for Aviation Fuel Handling

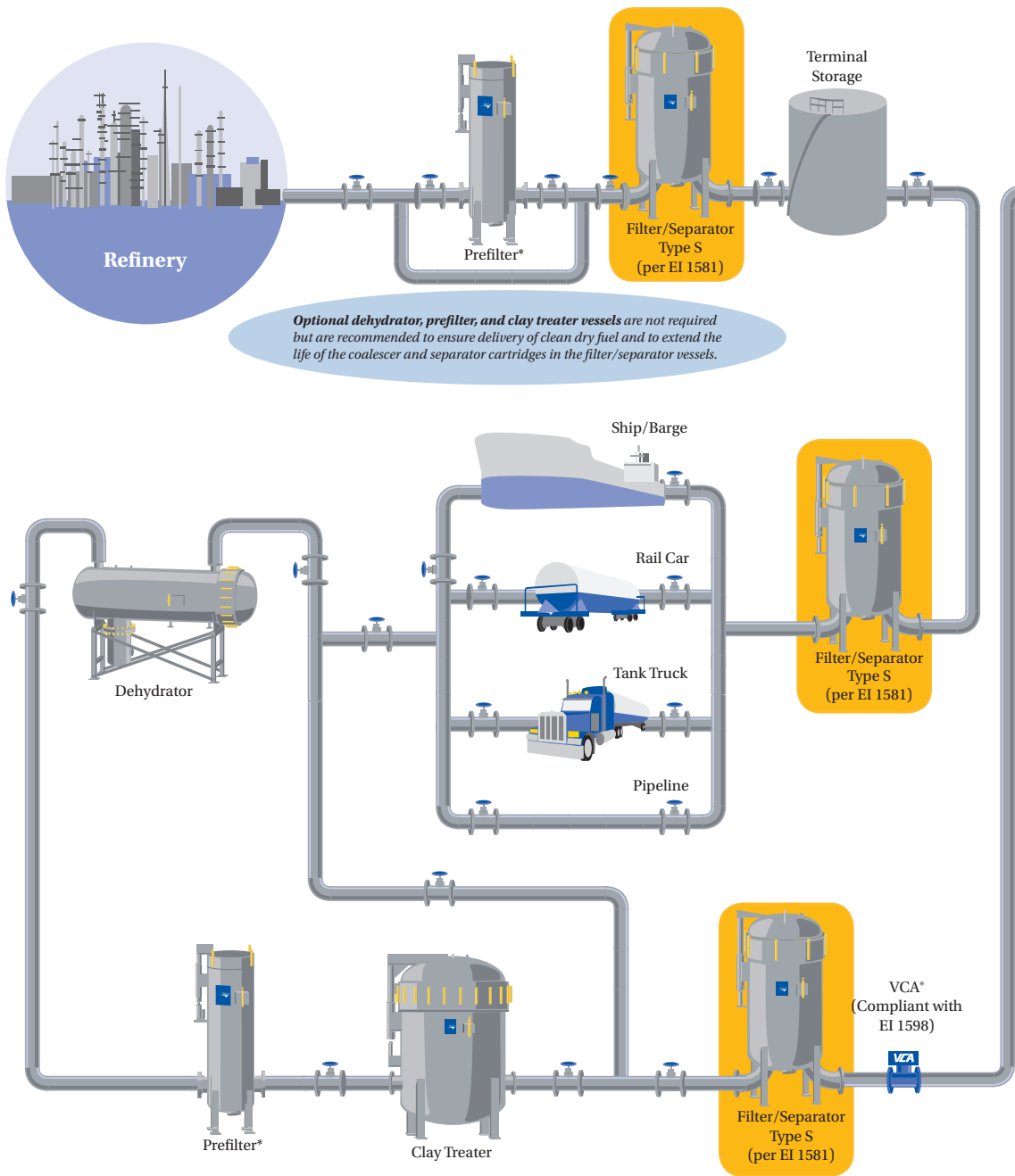

ENGINEERING YOUR SUCCESS.

Typical Distribution System for Clean Dry Aviation Fuel - Filter/Separator



CONTENTS

Coalescers I Series	4	Replacement Cartridges for Facet SuperFlex™ Housings O & SO Series	17
Separators SO Series	8	Vessel Selection Guidelines ...	19
Canister Separator SI Series	10	EI 1581 6th Edition	
Military Coalescer I-4xxA4 & MM Series	11	Specification Summary	20
Coalescer/Separator OS Series	13	Similarity Certification Form ...	21
Replacement Cartridges for Vel-Max® Housings O & SO Series	15	SO-6xxG Separator Assembly Installation Instructions	23
		Maintenance Instructions SO Series Separators.....	24
		Cartridge Changeout Curve ...	25

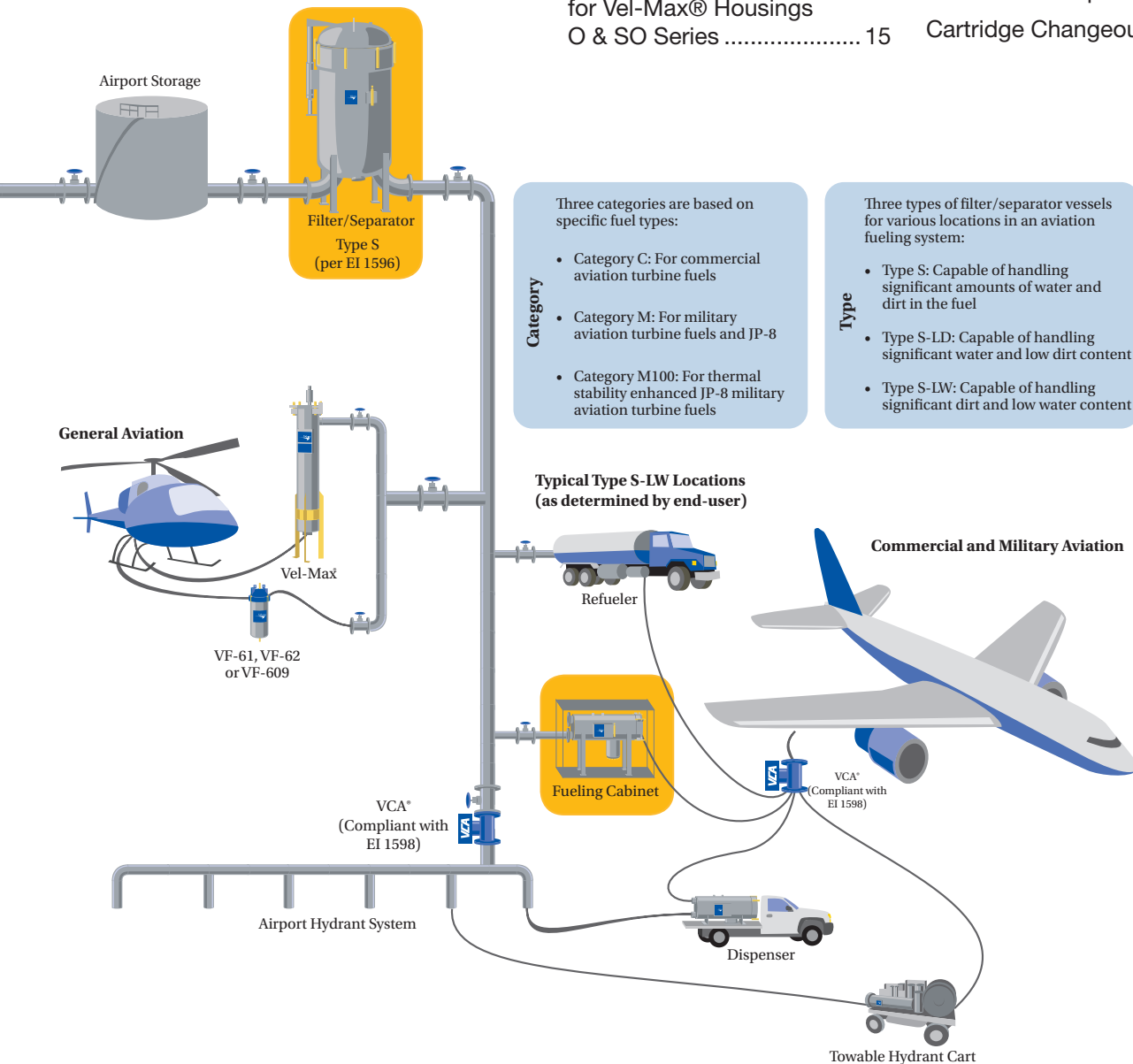

* Prefilter elements compliance with EI 1590 and vessel compliance with EI 1596 is customer dependent.
Optional EI 1583 Qualified Vessels/Absorbent Type Cartridges for jet fuel without anti-icing additive.

Cartridges for Water Removal from Aviation Fuel

I Series Coalescer



FEATURES:

- Cost effective particle and emulsified water removal from hydrocarbon fluids
- Easy installation and replacement with one-piece design
- Choice of Threaded Base or Open End cartridges
- Choice of All-Fiberglass Media or Combination Fiberglass and Pleated Media
- Field proven performance
- Ongoing qualification testing to meet changing commercial and military requirements
- Used as a first-stage cartridge in Filter/Separator
- Remove particulates and coalesce water into large water drops

HOW COALESCERS WORK:

Coalescer cartridges are employed as the first stage in filter/separator vessels for hydrocarbon fluids. They perform two functions: (1) coalesce (combine) highly dispersed, emulsified water particles into larger water drops and (2) filter-out particulate contaminants.

The left photo below shows a highly magnified view of the coalescing process. Tiny droplets of water contact and adhere to strands of fiberglass. Flow pushes the droplets along the strand

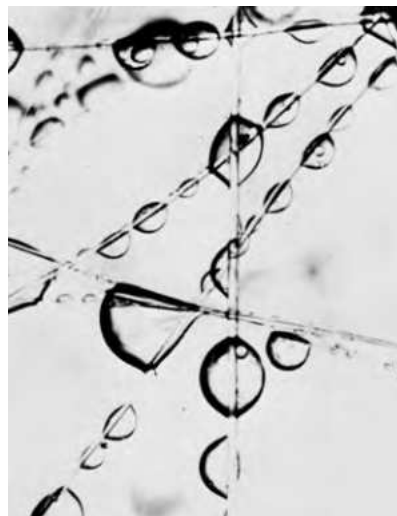

Photomicrograph of coalescing process inside fiberglass media.

until they reach an intersection of strands where they combine with other droplets (coalesce) into large drops.

These large drops are then carried to the outside surface of the cartridge. Having a higher specific gravity than the hydrocarbon fluid, they release and gravity pulls the droplet to the bottom of the vessel. The larger the drops, the faster and more efficiently they fall out (see bottom photo). In general, particle removal efficiency increases



Coalesced water drops releasing from the knitted sock at the outside surface of the cartridge.

with coalescing efficiency. This is accomplished by employing a tighter, finer filtration media.

Flow direction is from inside to outside of the cartridge. This minimizes surface velocity and helps prevent the water drops from breaking up and being carried downstream.

APPLICATION

Coalescer cartridges are used primarily to coalesce emulsified water and remove particles from hydrocarbon fluids. The largest single application is the filtration of aviation jet fuel. They are also used with other types of fuels, process streams in refineries and petrochemical plants, and condensate streams where natural gas is produced.

Other liquids can be separated if they are immiscible, the specific gravities differ, and high concentrations of surface active agents are not present. As a rule of thumb, if a sample of the mixture readily separates in an hour or two, a coalescer can probably be used. If the mixture hasn't separated after 24 hours, coalescing probably won't work.

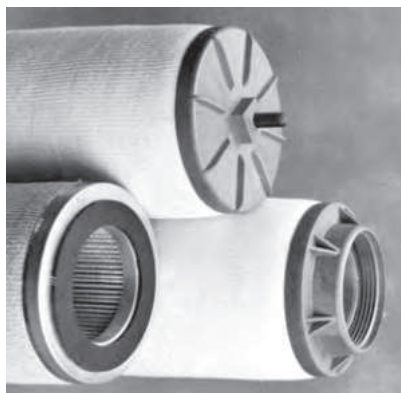

6" Diameter Threaded Base and Open End Coalescer End Caps

CONSTRUCTION

Parker Velcon single-unit coalescer elements are offered with Threaded Base or Open Ends and with Fiberglass Media or Fiberglass and Pleated Media combinations.

Threaded Base Coalescers are recommended for use in most applications. They simplify installation and replacement by eliminating the need for cover plates, center plates, nuts, washers, and gaskets. They are for use in Parker Velcon and other make filter/ separators. Threaded base adapters are available to convert vessels presently using open end elements.

Open End Coalescers are offered with single unit construction which reduces the number of gasket seals and improves overall reliability.

All-fiberglass Media Coalescers combine depth particulate filtration with a deep coalescing structure. All-fiberglass designs have successively finer media layers to achieve depth-type filtration of particles.

Combination Fiberglass and Pleated Media Coalescers remove particles primarily in the high surface area pleated core. They have one or more layers of pleated media inside a cylinder of molded fiberglass laminations to provide an extended surface area for particulate filtration. Pleat corrugation and separation materials are used to keep pleats open for full utilization.

Coalescing and filtration performance depends largely on the fiber diameter and bulk density of the fiberglass media. Both the All-Fiberglass and the Combination coalescer cartridge designs incorporate phenolic resin impregnated fiberglass media. Several grades with fiber

diameters ranging from 1 to 10 microns are used in various combinations to achieve desired results. Parker Velcon coalescer designs (85, 87 and C5 series cartridges) achieve even higher filtration and coalescing efficiency by incorporating pure micro-glass fibers with diameters of less than 1 micron in the pleated media.



All-Fiberglass "6" Series Coalescer



Fiberglass and Pleated Media "87" Series Coalescer



6000T Threaded Base Adapter

DESCRIPTION

Model Number System.

Refer to the box at right. The one or two digit Series Designator relates to the approximate micron rating of each model coalescer cartridge. Note that this is a nominal rating and should be used for reference only.

The “0”, “2”, and “4” Series all-fiberglass cartridges are rated at 25, 5, and 3 microns respectively. The “2” and “4” Series are commonly used with diesel and other fuel oils, and are a compromise between filtration efficiency (cartridge life) and water removing capability. They coalesce gross water, but normally do not remove fine water haze.

The all-fiberglass “6” Series was originally developed for jet fuel service (the original MIL-F-8901 specification). With a 2-micron rating, it has proven to be the most cost effective design in some jet fuel applications. “6” Series cartridges are also used in gasoline filtration service. However, it should be noted

that the powerful detergent additives in most automotive gasolines reduce the coalescing capability of this and other cartridge designs.

“83” Series Cartridges.

The 1-micron rated “83” Series is a pleated media/fiberglass cartridge. The very practical “83” Series cartridges have become the most widely used design in applications including gasoline, condensate, and insulating oil filtration.

“85” and “87” Series Cartridges.

The “85” Series is rated at 0.5-micron while the “87” Series is rated at 0.3 micron. Both incorporate multi-layered pleated media. The “85” Series has consistently shown superior dirt holding capacity in the field.

JF5 Series Coalescers.

JF5 Series Cartridges are Parker Velcon’s newest design. Combined with V5N5 Series Separators, they offer higher flow rates and extended service life.

EI* 1581 6th Edition Cartridges.

I-6xxC5 (TB), I-6xxMM, and I-6xxA4 Series of coalescers incorporate a multi-layered pleated media designed to provide superior dirt holding capacity in the field, combined with 0.4 micron efficiency. The I-6xxC5 (TB) replaces both the I-6xx85 (TB) and I-6xx87 (TB) cartridges. These cartridges are available in either threaded base or open-end configuration. See pages 7, 20 & 21 for more specific information on EI 1581 6th Edition.

Cartridge Dimensions. 6” diameter cartridges are the current industry standard. They are offered in lengths of 11”, 14”, 22”, 28”, 33”, 38”, 44”, and 56”. However, not all series are available in all lengths or in both end cap designs.

4” diameter cartridges are also offered for use with older equipment. They are available in a variety of lengths ranging from 8 to 40 inches.

Parker Velcon Model Numbers include significant product information. **Example:**

I - 6 2 8 C 5 T B

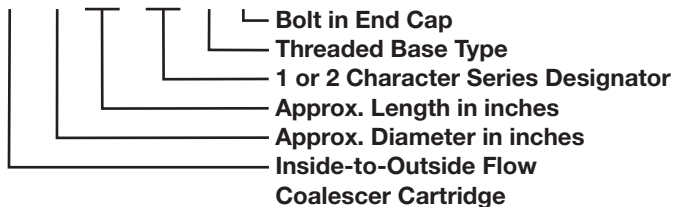

Note that I-628C5 would designate the open end version of this cartridge.

GENERAL SPECIFICATIONS

- 75 psi maximum pressure differential rating
- 5 to 9 pH range
- 250°F (121.1°C) maximum operating temperature
- Aluminum center tube
- Buna-N gaskets
- Injection molded end caps are standard on 6” diameter threaded base coalescers;
- Aluminum end caps are standard on 6” diameter open end cartridges
- All 6” diameter cartridge end caps are bonded directly to the media with high strength epoxy or urethane
- 4” diameter cartridge have molded polyester resin or injection molded end caps

*EI (Energy Institute) is the new specification authority. API (American Petroleum Institute) is no longer involved in aviation fuel filtration specifications.



EI1581 6TH EDITION QUALIFIED COALESCERS

The I-6xxC5 (TB), I-6xxMM, I-6xxA4, and I-6xxJF5 (TB) Series coalescers (“xx” denotes nominal cartridge length) incorporate multi-layered pleated media designed to provide superior dirt holding capacity in the field, combined with 0.4 micron efficiency. The I-6xxC5(TB) replaces both Parker Velcon’s I-6xx85(TB) and I-6xx87(TB) cartridges. These cartridges are available in either threaded base or open-end configuration.

CATEGORY FUELS

Parker has tested and qualified a comprehensive range of products to meet the EI 1581 6th Edition Specification.

CATEGORY C

This category replaces the previous class A, B, & C of EI 1581 Third Edition. Parker Velcon’s new coalescer cartridges that meet Category C requirements are the I-6xxC5 Series (“xx” denotes nominal cartridge length). These cartridges have been developed to provide better water removal performance in surfactant-laden fuels, and improved filtration efficiency combined with longer life. Category ‘C’ cartridges can be used at any point in the fuel distribution system – from refineries to into-plane fueling.

CATEGORY M

This category covers military fuels, such as JP8 (similar to Jet A but containing anti-icing and other additives). Parker Velcon’s coalescer products for this category are the I-6xxMM Series cartridges.

Category M qualified cartridges also qualify for Category C.

CATEGORY M100

This category is for military fuels such as JP8+100. The ‘+100’ additive allows fuels to run at higher operating temperatures and reduces maintenance for high performance military jet engines. Parker Velcon’s coalescer cartridges for the M100 Category are the I-6xxA4 Series.

ADDITIONAL INFORMATION

The 6th Edition also allows operators to incorporate third stage filter cartridges with each category. Parker has currently qualified the CDF®-2xx Series monitor (water absorbing) cartridges for Category C and the FOW-2xx Series filter cartridges for Category M100.

Another aspect of the EI 1581 6th Edition specification is the description of filter/separators as Type S (water and dirt), Type S-LW (for applications where low amounts of water are expected) and Type S-LD (for applications where low amounts of dirt are expected). Products qualified for Type S are also qualified for Types S-LD and Type S-LW.

To obtain your authorized Parker EI 1581 6th Edition Similarity Data Report for existing vessels, please complete the Similarity Certification form (VEL1728 or page 22).



I-614C5TB Coalescer



EI 1581 6th Edition Separator and Coalescer

Separator Cartridges

Filter/Separator 2nd Stage Elements

FEATURES

- Optimum 2nd stage water removal
- Choice of PTFE Coated Screen, Synthetic or Pleated Paper Media
- Field proven performance
- Largest selection of replacement elements

DESCRIPTION

Separator Cartridges are employed as the second stage in filter/ separator vessels. Their sole function is to repel coalesced water drops produced by the first stage cartridges while allowing hydro-carbon fluids to pass through. Water drops settle into the filter/ separator sump and are not carried downstream. All particle filtering is done by the first stage coalescer cartridge.

Flow direction is from outside-to-inside. The top photo insert shows water being repelled by the hydrophobic separator medium on the cartridge's outside surface. Hydrocarbon fluids, on the other hand, easily pass through and exit the separator cartridge. Cartridges with three different types of repelling media are offered:

PTFE Coated Screen (PCS) Cartridges are, by far, the most popular type of separator cartridge. With proper cleaning and inspection, cost effective PCS elements can be reused over many changeout cycles. And, PCS cartridges generate considerably less static charge than pleated paper cartridges. These features have made them the preferred choice for aircraft fueling applications.

Pleated Paper Cartridges cannot be reused and are replaced at every coalescer cartridge changeout. They are often used with diesel and other fuel oils which may contain materials that adhere to PCS cartridges and cannot be cleaned off.

Synthetic Media Cartridges can be cleaned a maximum of two times. They are intended for customers who do not want to take the time to clean and re-use separators.

SEPARATOR CARTRIDGE PERFORMANCE

Maintaining a uniform flow along the length of the cartridge optimizes performance and reduces the number of cartridges required. Flow is controlled by a tube, inside each cartridge, through which the hydrocarbon fluid exits the cartridge and the filter/separator vessel. Two styles of inner tube are offered. See bottom photo.

Cartridges with uniform hole pattern inner tubes are adequate for many applications. However, where optimum flow distribution is required, cartridges with variable hole pattern inner tubes are recommended. When converting older equipment, a lesser number of variable hole pattern cartridges is usually required. Operating costs will therefore be reduced.

SEPARATOR CARTRIDGES

Model numbers containing a "C" in denotes a uniform hole pattern on the inner tube with PCS media, while the codes with a "V" signifies a variable hole pattern with PCS media. Blind caps have a hole for the tie rod.

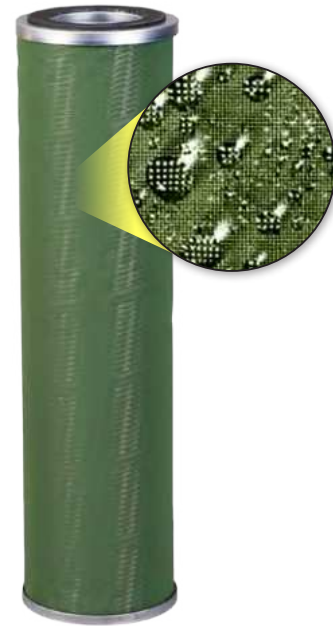

Coalesced water drops from the first stage are shown (above) intruding upon the surface of the PCS Separator Cartridge. The droplets are repelled by the PTFE coated screen, enabling the droplets from passing through. The screen magnification shows how the droplets form on the surface of the PTFE coating.

INNER TUBE HOLE PATTERN



Uniform Variable

Velcon Model Numbers include significant product information. **Example:**

S O - 6 3 6 P V

- Code identifying Media, Tube Type, and End Cap Design
- Approx. Length in inches
- Approx. Diameter in inches
- Outside-to-Inside Flow Separator Cartridge

CARTRIDGE CODE IDENTIFICATION

Model	Flow Control (perforation)	Dimensions (inches)			Media
		OD	Mounting End ID	Opposite End ID	
SO-3xxC	Uniform	3 $\frac{1}{16}$	2	Blind	PCS
SO-3xxV	Variable	3 $\frac{1}{16}$	2	Blind	PCS
SO-4xxC	Uniform	4 $\frac{1}{16}$	3 $\frac{1}{2}$	Blind	PCS
SO-4xxV	Variable	4 $\frac{1}{16}$	3 $\frac{1}{2}$	Blind	PCS
SO-6xxC	Uniform	6	3 $\frac{1}{2}$	3 $\frac{1}{2}$	PCS
SO-6xxCA	Uniform	6	3 $\frac{1}{2}$	Blind	PCS
SO-6xxCM	Uniform	6	4 $\frac{1}{2}$	Blind	PCS
SO-6xxVA(5)	Variable	6	3 $\frac{1}{2}$	Blind	PCS
SO-6xxV(5)	Variable	6	4 $\frac{1}{2}$	Blind	PCS
SO-6xxPV(5)	Variable	6	4 $\frac{1}{8}$	Blind	PCS
SO-6xxPLF3*	Uniform	6	3 $\frac{1}{2}$	3 $\frac{1}{2}$	Pleated Paper
SO-6xxPLBZ*	Uniform	6	3 $\frac{1}{2}$	Blind	Pleated Paper
SO-6xxVASN(5)	Variable	6	3 $\frac{1}{2}$	Blind	Synthetic
SO-6xxVSN(5)	Variable	6	4 $\frac{1}{2}$	Blind	Synthetic
SO-6xxPVS(5)	Variable	6	4 $\frac{1}{8}$	Blind	Synthetic

*The shelf life for pleated paper separators (for example, SO-xxxPLF3 and SO-6xxPLBZ) is one year.

SPECIFICATIONS

- PCS medium is 200 mesh stainless steel screen coated on both sides with green PTFE
- The screen is lockseam folded and fastened with an internal aluminum clip
- Pleated medium is silicone treated resin impregnated paper with a protective outer aluminum screen jacket
- Aluminum Tube
- Aluminum and/or glass filled nylon endcaps
- Buna-N gaskets
- pH range: 5 to 9
- Maximum operating temperature: 250°F (121.1°C)

SO SERIES CARTRIDGES

The code identification table to the left are the most commonly used. A variety of other styles are available for special applications. Contact a local area distributor for details.

SO-6xxPLF3 pleated separators

come in lengths of 11,14, 16, 29, and 33 inches. SO-6xxPLBZ pleated separators come in lengths of 22, 29, 33, and 44 inches.

SO-6xxC cartridges are available in these same stackable lengths plus longer lengths. Single-unit designs, however, are recommended for installation ease and lower cost. Other styles listed in the table are not intended to be stacked.

Parker Velcon variable size hole pattern cartridges should not be replaced with uniform hole pattern cartridges unless appropriate full-scale test data can be supplied showing equivalent performance.

SO-6xxVASN/VSN/PVS(5) separators are intended for customers who want a separator for disposal use rather than a re-useable filter, which can be cleaned a maximum of two times.

EI 1581 6TH EDITION QUALIFIED SEPARATORS

The SO-6xxV5, SO-6xxPV5, and

SO-6xxVA5 are PTFE Coated Screen (PCS) cartridges. SO-6xxVSN(5), SO-6xxPVS(5), and SO-6xxVASN (5) are synthetic separator cartridges. To achieve optimum flow distribution all of these cartridges incorporate a variable hole pattern inner tube combined with a uniform hole pattern outer tube specifically designed for installation in vertical filter/separators. Please refer to literature form VEL1521 for overall separator dimensions and general specifications.

CATEGORY FUELS

Parker AFD tests and qualifies a comprehensive range of products to meet the EI 1581 6th Edition Specification.

CATEGORY C

All of our PCS Separator Cartridges are qualified for Category C.

CATEGORY M

This category covers military fuels, such as JP8 (similar to Jet A but containing anti-icing and other additives). Separators for this category are currently PCS Separators SO-6xxV5, SO-6xxVA5, and SO-6xxPV5, as well as Synthetic Separators SO-6xxVSN, SO-6xxPVS(5), SO-6xxVSN5 and SO-6xxVASN.

Category M qualified cartridges also qualify for Category C.

CATEGORY M100

This category is for military fuels such as JP8+100. The PCS Separators for M100 are currently the SO-6xxCM and SO-6xxGS (three-stage).

To obtain your authorized EI 1581 6th Edition Similarity Data Report for existing vessels, please complete Velcon Similarity Certification form VEL1728.



Canister Separator

SI Series

Fully Qualified to EI 1581 6th Edition, Category M

DESCRIPTION

The SI-xxxx Series separator canister is composed of an inner PTFE-coated 200 mesh screen. The open endcap on the five inch canister has a locking bayonet mount with wavy spring. The blind end has a nozzle to fit a DOD coalescer o-ring endcap.

These separators are qualified to Category M and M100 of the EI 1581 6th Edition Specification.

APPLICATION

The SI-xxxx Series separator canisters are made to fit over first stage coalescers in DOD military vessels such as those originally made to the MIL-F-27629, MIL-F- 27630, and MIL-PRF-52308 specifications.

The inner PTFE coating repels water droplets as fuel exits the canisters, adding another layer of protection to the fueling system. The water droplets in the annular gap between the outside diameter of the coalescer and the inside diameter of the separator canister fall to the sump area at the bottom of the filter vessel, where they can then be drained.

SPECIFICATIONS

Model #	NSN #	OAL (in.)	OD (in.)	ID (in.)	Micron Rating (µm)
SI-422A*	4330-01-152-2376	21.56	4.46	4	140
SI-443*	4930-01-561-5968	43	4.6	4.5	140
SI-522	4330-01-511-8316	22.44	5.23	4	140
SI-522E	4330-00-112-0256	22.44	5.23	4	140
SI-542	4330-01-511-8274	42.5	5.23	4	140

**SI-422A and SI-443 have open endcap with no bayonet mount, and are not EI 1581 qualified. SI-443 is not qualified to any of the MIL specs listed above.*

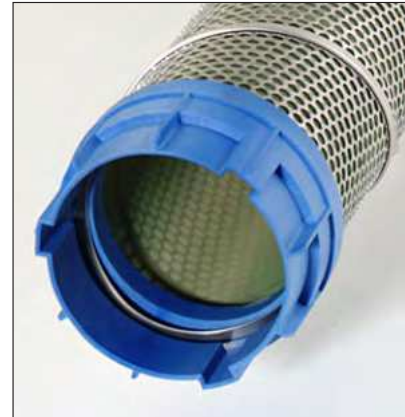

Open endcap with bayonet mount



SI-542 Separator

Military Coalescer

I-4xxA4 & MM Family

Qualified to EI 1581 6th Edition, Category M, M100,
MIL-PRF-52308J, MIL-PRF-32148

DESCRIPTION

The I-4xxMM filter/coalescer cartridge has an internal multi-layer pleat block with a large surface area for greater dirt holding capacity. A fine fiber micro-glass shell provides optimum water removal characteristics. The advanced composition of our "MM" Series media allows most vessel configurations to meet EI 1581 6th Edition, Category M, performance requirements.

Identical in form and fit to the I-4xxMM, the I-4xxA4 filter/coalescer cartridges allows most vessel configurations to meet EI 1581 6th Edition, Category M100 performance requirements.

APPLICATION

These cartridges are designed to fit in DOD military vessels such as those originally made to the MIL-F-27629 and 27630 specifications.

I-440MM filter/coalescer (NSN 4330-01-511-8268) has been specifically designed to replace a stack of two standard DOD filter/coalescers (NSN 4330-00-983-0998). The I-440MM is also a direct replacement for the previous 3rd Edition model, I-44087 (NSN 4330-01-407-3548).

An objective of the 40-inch cartridge is to eliminate three potential leakage points (there are o-rings at each end of a 20-inch cartridge). The I-440MM has a top blind end and an o-ring at the lower end. Use one Gammon GTP-5935-M alignment pin in the top blind cap to provide a locator for



Top—Blind cap



Bottom—Mounting end with O-ring seal



GTP-5935-M Alignment Pin

spider plate alignment.

I-440MM has an o-ring at each end to accommodate a few existing filter/separator vessels that use tie rods instead of spider plates to hold the cartridges. I-420MM (NSN 4330-01-511-8209) and I-420MMA (NSN 4330-01-477-7985), the 20-inch coalescers, also have an o-ring at each end and are direct replacements for the 20-inch DOD cartridge. No alignment pin is required for any of these models.

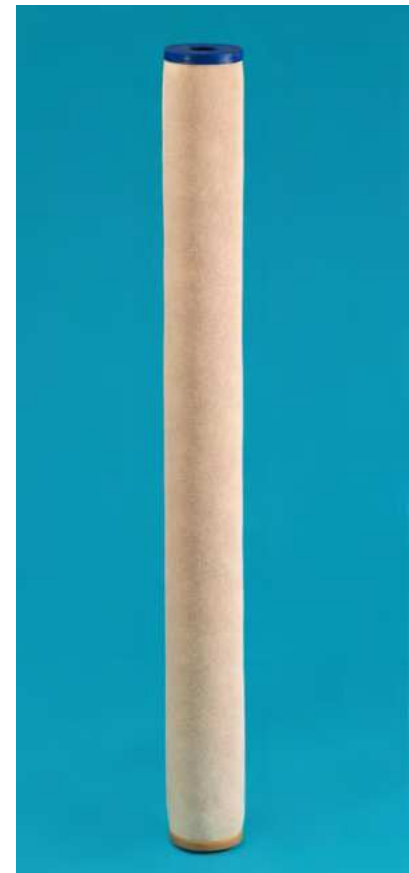

I-440MM*

* I-440AMM: Alternative version with O-Ring seals on both ends

CARTRIDGE SELECTION

Parker Velcon P/N	NSN (National Stock Number)	Spec.	Dim (in.)		Endcaps	Seal	Blind Cap	Max Rated Flow (USGPM)
			OAL	OD				
I-420A4	4330-01-548-4867	Category M100: EI 1581, 6th Ed.	20	3.625	Injection molded glass filled nylon 6/6	O-ring, both ends	N/A	20
I-420MM	4330-01-511-8209	Category M: EI 1581, 6th Ed. and MIL-PRF-52308J						
I-420MMA	4330-01-477-7985							
I-420MMF	4330-00-931-2472	MIL-PRF-32148	20.125	3.75	Aluminum	Flat gaskets	N/A	17.5
I-424MMF	4330-00-931-2473		24.125	3.75	Aluminum	Flat gaskets	N/A	21
I-440A4	4330-01-548-6906	Category M100: EI 1581, 6th Edition	39.875	3.625	Injection molded glass filled nylon 6/6	O-ring, one end	Opposite End	40
I-440MM	4330-01-511-8268	Category M: EI 1581, 6th Ed. and MIL-PRF-52308J	39.875	3.625	Injection molded glass filled nylon 6/6	O-ring, one end	Opposite End	40
I-440AMM	N/A	Category M: EI 1581, 6th Ed.	39.875	3.625	Injection molded glass filled nylon 6/6	O-ring, both ends	N/A	40
I-620MM	4330-01-516-6994	Category M: EI 1581, 6th Ed.	20.125	6.0	Aluminum	Flat gaskets	N/A	45.5

SPECIFICATIONS

- Changeout Differential Pressure: 15 psid
- Maximum Pressure Ratio: 75 psid
- Maximum Operating Temperature: 250°F (121.1°C)
- Micron Rating: 0.4

OS Series Coalescer/Separator Cartridges

Designed for superior performance in VF-61, VF-609, Racor's FBO-10 and FBO-14 Housings, Facet's VFCS-21 & VFCS-22 Filter/Separator Vessels

FEATURES

- Can be used with pre-mixed fuel containing anti-icing additive
- One piece replacement combination coalescer and separator cartridge
- OS-51288 Cartridge: Laboratory tested to 0.2% water in incoming fuel, 10 ppm in effluent*
- PTFE coated screen separator
- Reliable radial sump seal design
- Nominal 0.5 micron particle efficiency for jet fuel and avgas; 5 micron for diesel fuel
- Minimum 75 psid collapse strength
- Flow direction – outside to inside
- Operating temperatures up to 250°F (121.1°C)
- 5 - 9 operating pH range

The OS Series combination coalescer/separator cartridges filter dirt and remove water from aviation and diesel fuels. They are designed to fit into VF-61, VF-609, Racor's FBO-10 & FBO-14 housings, Facet's VFCS-21 and VFCS-22 filter/separator housings.

Performance is improved due to PTFE coated screen separators and reliable radial sump seals.



OS-51288 Cartridge



OS-60988 Cartridge

*Fuel was additive free and tested at 35USGPM

DESCRIPTION

Flow is from outside to inside through the cartridge. Coalesced water is repelled by the separator and drops to the sump for daily draining. Clean, dry fuel exits the cartridge through the nozzle at the top.

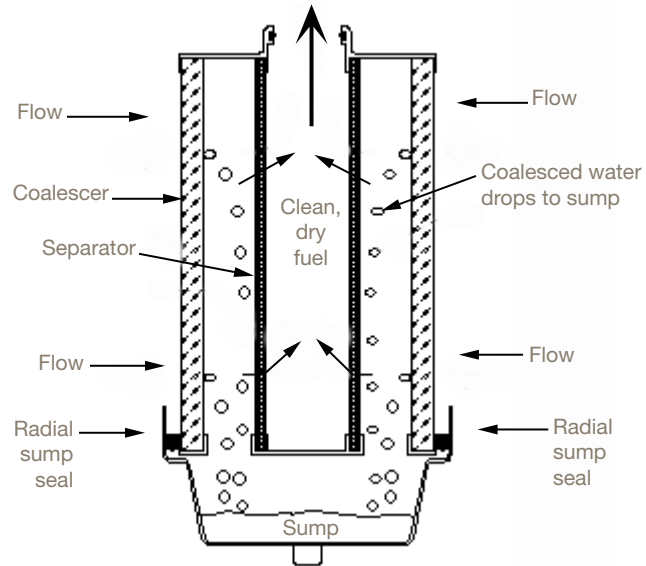

CARTRIDGE SELECTION TABLE

MODEL NUMBER	VESSEL MODEL NUMBER	FOR PRODUCT	FLOW RATE USGPM (max)	MICRON RATING	DIMENSIONS			
					OD		LENGTH	
					in.	mm	in.	mm
OS-51288	VF-61	Jet Fuel/ Avgas	35/45	0.5	6	152	11 ³ / ₄	298
OS-60988	FBO-10, VF-609 VFCS-21	Jet Fuel/ Avgas	35/45	0.5	6	152	9	229
OS-61288	FBO-14 VFCS-22	Jet Fuel/ Avgas	50/60	0.5	6	152	13	330
OS-51286	VF-61	Diesel Fuel	18	5	6	152	11 ³ / ₄	298
OS-60986	FBO-10, VF-609 VFCS-21	Diesel Fuel	18	5	6	152	9	229
OS-61286	VFCS-22, FBO-14	Diesel Fuel	24	5	6	152	13	330

Replace the cartridge when the differential pressure exceeds 15 psi or after 1 year of service, whichever occurs first.

*Because of the limited sump space in these vessels, IT IS IMPERATIVE to drain the sump at EVERY FUELING. It is also important to recognize that these OS cartridges by themselves do not provide a water defense system. One water defense option is to use the Water Detection Probe, Velcon part number 125-Q.

Replacement Cartridges for Vel-Max® Housings

O Series Coalescer and SO Separator Remove Water and Dirt from Diesel, Jet Fuel and Avgas

- Reduces free and emulsified water to less than 50 ppm in diesel, and less than 15 ppm in jet fuel/avgas.
- Used in place of Aquacon® cartridges for continuous removal of free water
- For use in the Parker Velcon Vel-Max® housings

DESCRIPTION

The Parker Velcon coalescer and separator are installed together in the Vel-Max® housing to remove water and dirt from fuel. The fuel passes from the outside to the inside through the coalescer. Dirt is filtered out of the fuel and free/emulsified water in fuel is coalesced. The coalesced water droplets, which form on the inside of the coalescer, are repelled from going further down-stream by the separator. The water settles down to the sump where it is manually drained.

SPECIFICATIONS

- Maximum Operating Temperature is 250°F (121.1°C)
- Flow direction: outside to inside
- pH range: 5 to 9
- Coalescer Changeout at 15 psid

MAXIMUM RECOMMENDED FLOW RATES

Housing with Cartridges	Jet		Avgas		Diesel	
	gpm	lpm	gpm	lpm	gpm	lpm
VX-1	37	140	55	208	25	95
VX-2	75	284	100	378	50	189
VX-3	112	424	168	636	75	284

For more information on the Vel-Max® Filter Vessel please refer to data sheet VEL1961. Vel-Max® and Aquacon® are registered trademarks of Parker Hannifin.



O-81588 and SO-415VX5 Separator

VEL-MAX® FILTER/SEPARATOR CONFIGURATION

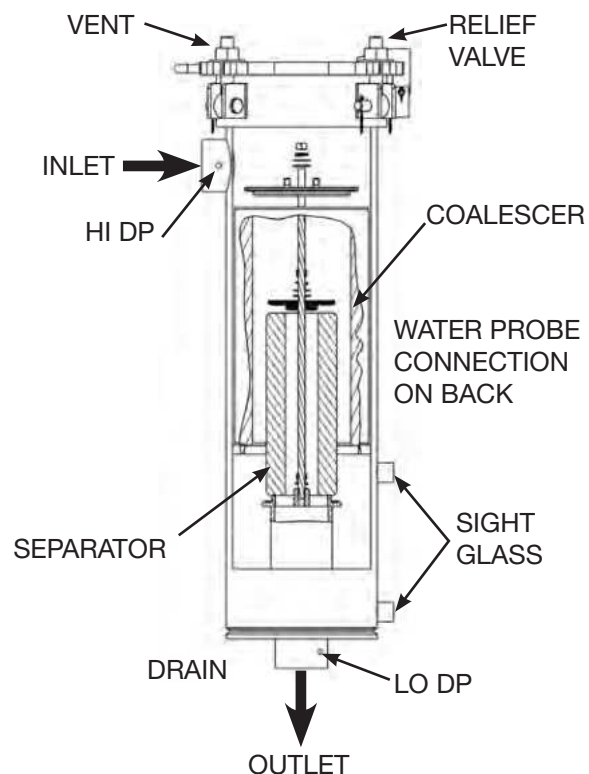

CARTRIDGE SELECTION TABLES FOR VEL-MAX® HOUSINGS

JET & AVGAS APPLICATIONS

Model	Cartridge	Model #	Micron Rating	Dimensions (in.)		
				OAL	ID	OD
VX-1	Coalescer	O-81588	0.5	15.0	5.625	7.625
	Separator	SO-415VX5	N/A	15.0	1.875	4.0
VX-2	Coalescer	O-83088	0.5	30.0	5.625	7.625
	Separator	SO-430VX5	N/A	30.0	1.875	4.0
VX-3	Coalescer	O-84488	0.5	44.0	5.625	7.625
	Separator	SO-444C	N/A	44.0	1.875	4.0

NOTES:

1. If converting from Parker Velcon **Aquacon**® water absorbing cartridges to coalescer/separator cartridges, please order **Part Number EA35** end seal plate.
2. Separators used for jet fuel and avgas applications (SO-4xxVX5) are PTFE-coated and can be cleaned and re-used. See data sheet VEL1242 for cleaning and maintenance instructions.
3. Separators used for diesel applications (SO-4xxPL) are made with pleated media. Changeout at 15 psid.

DIESEL APPLICATIONS

Model	Cartridge	Model #	Micron Rating	Dimensions (in.)		
				OAL	ID	OD
VX-1	Coalescer	O-8150	25	15.0	5.625	7.625
	Coalescer	O-8152	5			
	Coalescer	O-8156	2			
	Separator	SO-415PL	N/A	15.0	1.875	4.0
VX-2	Coalescer	O-8300	25	30.0	5.625	7.625
	Coalescer	O-8304	3			
	Coalescer	O-8306	2			
	Separator	SO-430PL	N/A	30.0	1.875	4.0
VX-3	Coalescer	O-8440	25	44.0	5.625	7.625
	Coalescer	O-8444	3			
	Coalescer	O-8446	2			
	Separator	SO-444PL	N/A	44.0	1.875	4.0

For information on other types of Parker Velcon filter cartridges that can be used in the Vel-Max® Housing, see below and corresponding data sheet as marked.

Application Type		1-High	2-High	3-High
Micronic Filter Cartridges	Pleated Paper	FO-614PLFxx*	FO-629PLFxx	FO-644PLFxx
	Fiberglass Depth	FO-614FGxx	FO-629FGxx	FO-644FGxx
Aquacon ® Cartridges	Jet Fuel/Avgas	ACO-61401R	ACO-62901R	ACO-64401R
	Gasoline	AC-61405	AC-62905	AC-64405
	Diesel	AD-61425	AD-62925	AD-64425
CDF®	Jet Fuel	CDF-215P	CDF-230P	N/A

*The suffix "xx" on the part number denotes the micron rating of the cartridge.
Example: FO-614PLF5 is a 5 micron filter.

Replacement Cartridges for Facet SuperFlex™ Housings

O Series Coalescer and SO Separator Remove Water and Dirt from Diesel, Jet Fuel and Avgas

- Reduces free and emulsified water to less than 50 ppm in diesel, and less than 15 ppm in jet fuel/avgas.
- Used in place of Aquacon® cartridges for continuous removal of free water
- For use in the Facet SuperFlex housings in diesel and jet fuel/avgas service

DESCRIPTION

The Parker Velcon coalescer and separator are installed together in the Facet SuperFlex housing to remove water and dirt from fuel. The fuel passes from the outside to the inside through the coalescer. Dirt is filtered out of the fuel and free/emulsified water in fuel is coalesced. The coalesced water droplets, which form on the inside of the coalescer, are repelled from going further down-stream by the separator. The water settles down to the sump where it is manually drained.

SPECIFICATIONS

- Maximum Operating Temperature is 250°F (121.1°C)
- Flow direction: outside to inside
- pH range: 5 to 9
- Coalescer Changeout at 15 psid

MAXIMUM RECOMMENDED FLOW RATES

Housing with Cartridges	Jet		Avgas		Diesel	
	gpm	lpm	gpm	lpm	gpm	lpm
1-High	37	140	55	208	25	95
2-High	75	284	100	378	50	189
3-High	112	424	168	636	75	284



O-81488 Coalescer and SO-412V5 Separator

SuperFlex Housing (1-High)

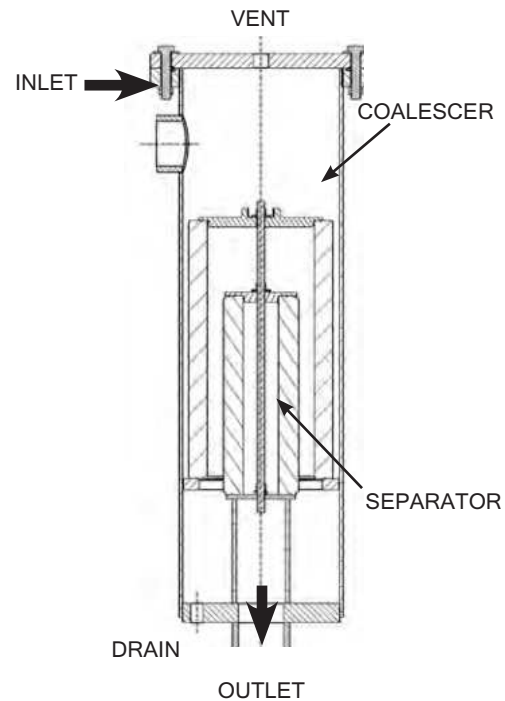

CARTRIDGE SELECTION TABLES FOR SUPERFLEX HOUSINGS

JET FUEL & AVGAS APPLICATIONS

Housing	Cartridge	Model #	Micron Rating	Dimensions (Inches)		
				OAL	ID	OD
1-High	Coalescer	O-81488	0.5	13.6875	5.625	7.625
	Separator	SO-412V5	N/A	11.5	1.875	4.0
2-High	Coalescer	O-82888	0.5	27.5	5.625	7.625
	Separator	SO-422V5	N/A	21.5	1.875	4.0
3-High	Coalescer	O-84288	0.5	41.3125	5.625	7.625
	Separator	SO-432V5	N/A	31.5	1.875	4.0

NOTES:

1. If converting from Parker Velcon's **Aquacon**® water absorbing cartridges to coalescer/separator cartridges, please order **Part Number EA35A** end seal plate.
2. Separators used for jet fuel/avgas applications (SO-4xxV5) are PTFE-coated and can be cleaned and re-used. See data sheet VEL1242 for cleaning and maintenance instructions.
3. Separators used for diesel applications (SO-4xxPL) are made with pleated media. Changeout at 15 psid.

DIESEL APPLICATIONS

Housing	Cartridge	Model #	Micron Rating	Dimensions (Inches)		
				OAL	ID	OD
1-High	Coalescer	O-8140	25	13.6875	5.625	7.625
	Coalescer	O-8142	5			
	Coalescer	O-8144	3			
	Coalescer	O-8146	2			
	Separator	SO-410PL	N/A	10.5	1.875	4.0
2-High	Coalescer	O-8280	25	27.5	5.625	7.625
	Coalescer	O-8282	5			
	Coalescer	O-8284	3			
	Coalescer	O-8286	2			
	Separator	SO-422PL	N/A	21.5	1.875	4.0
3-High	Coalescer	O-8420	25	41.3125	5.625	7.625
	Coalescer	O-8422	5			
	Coalescer	O-8424	3			
	Coalescer	O-8426	2			
	Separator	SO-432PL	N/A	31.5	1.875	4.0

For information on other types of Parker Velcon filter cartridges that can be used in the SuperFlex Housing, see below and corresponding data sheet as marked.

Type		1-High	2-High	3-High
Micronic Filter Cartridges	Pleated Paper	FO-614PLFx*	FO-629PLFxx	FO-644PLFxx
	Fiberglass Depth	FO-614FGx	FO-629FGxx	FO-644FGxx
Aquacon ® Cartridges	Jet Fuel/Avgas	ACO-61401R	ACO-62901R	ACO-64401R
	Gasoline	AC-61405	AC-62905	AC-64405
	Diesel	AD-61425	AD-62925	AD-64425

*The suffix "x" or "xx" on the part number denotes the micron rating of the cartridge.
Example: FO-614PLF5 is a 5 micron filter.

Vessel Selection Guidelines

Aviation Fuel Filtration in commercial applications is governed by the complex, stringent requirements of EI 1581, 6th Edition. Refer to the appropriate Parker literature or contact your Parker representative for assistance. For non-aviation applications the following guidelines have proven to be useful. Note, however, that these guidelines are general in nature and should be used for guidance only.

1. Determine total length (inches) of 6" diameter cartridge required:
 - a. Find the approximate viscosity of your hydrocarbon fluid on the Chart Y-axis.
 - b. Find the corresponding Specific Flow Rate (gpm/ inch) on the X-axis.
 - c. Divide Total Flow Rate (gpm) of your application by this Specific Flow Rate to calculate total inches of coalescer required.
2. Select cartridge model and calculate quantity required:
 - a. Choose model (type and length) cartridge to use. 83 Series Coalescers are recommended for most applications. Other types and sizes are offered for special applications
 - b. Calculate minimum number of cartridges required by dividing total inches (from Step 1) by length of cartridge selected.
3. Select the Filter/Separator Vessel for your application:
 - a. Refer to the Parker Velcon literature for HV (horizontal) or VV (vertical) Filter/Separators.
 - b. Find the appropriate vessel for the model and quantity Coalescer Cartridge selected in Step 2.

NOTES

These guidelines assume a specific gravity of 0.92 or less, and an influent water concentration of 3% or less. In general, if the Interfacial Tension (IFT) of the hydrocarbon over water is 36 dynes per centimeter or greater, effluent water levels of 15 ppm or less can be achieved.

Surfactants will significantly lower IFT with a corresponding decrease in coalescing performance. Surfactants can occur naturally (diesel fuel) or they can be intentionally added as corrosion inhibitors (pipelines, lube and hydraulic oils) and detergent dispersants (automotive gasoline).

As previously discussed, diesel and fuel oils are a special category. 2 or 4 Series Coalescer Cartridges are commonly used. Pleated paper separator cartridges are typically specified since diesel often contains materials that adhere to PTFE separators and cannot be cleaned off - nullifying their cost effectiveness. Refer to Parker Velcon V Series Filter/Separator Vessels literature.

Oversizing filtration equipment improves performance and extends cartridge life.

Strong bases (high pH fluids) attack glass microfibers and break down the coalescing media. Caustic washing or applications with high concentrations of MEA or DEA should be limited.

Initial differential pressure (with clean coalescer cartridges) will be less than 5 psi. Cartridges should be changed when the differential pressure reaches 15 psi or after one year - whichever occurs first.

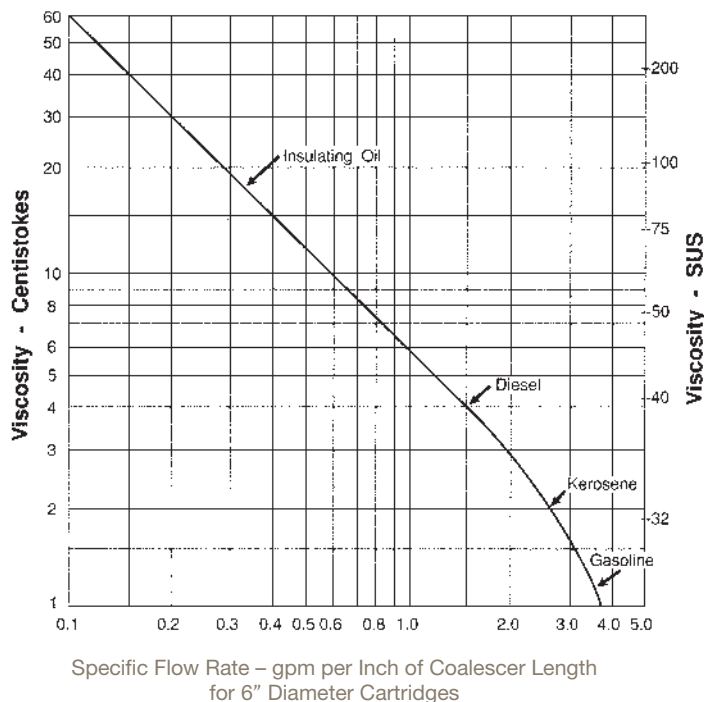

EI 1581 6th Edition Specification Summary

EI 1581 6th Edition Specification* Key Points

- Category “C” filter/separators are for use in commercial Jet-A or Jet-A1 fuel are tested in fuel containing anti-static additive Stadis 450 and corrosion inhibitor DCI-4A.
- Category “M” filter/separators are for use in military JP-8 or JP-5 fuel. They are tested in fuel containing Stadis 450, DCI-4A, and anti-icing additive Di-EGME. (Note: testing to Category “M” also qualifies for Category “C”.)
- Category “M100” filter/separators are for use in military JP8+100 fuel. They are tested in fuel containing Stadis 450, DCI-4A, Di-EGME, and thermal stability additive Spec Aid 8Q462.
- Type “S” filter/separators are used at filtration points where significant levels of both dirt and water can be expected. (Note: testing to Type “S” also qualifies for both Type “S-LD” and Type “S-LW”.)
- Type “S-LD” filter/separators are used at filtration points where significant levels of water but minimal amounts of dirt can be expected.
- Type “S-LW” filter/separators can be used for mobile applications where minimal amounts of water can be expected in the jet fuel.
- Type “S-M” filter/separators (a combination of the former type S-LD and S-LW) specifically intended only for some into-aircraft applications (fuellers, carts and hydrant dispensers).
- Multi-Stage Systems can be used at all filtration points in addition to filter/separators where additional performance is desired. Multi-stage devices can include upstream pre-filters and downstream water absorbing filters.
- The EI specification procedures qualify the entire filter/separator, not just the elements. Elements are used in an EI qualified filter/separator but the qualification would apply to the corresponding elements and vessels as a whole.
- A filter/separator of similar geometry to the tested vessel can be qualified by similarity providing that a complex set of criteria are met. This is particularly significant in establishing EI qualification for existing equipment in the field.
- Including within scope, filter/coalescer elements with nominal diameters of 50 mm (2 in.) and 100 mm (4 in.)
- In order for a filter/separator to be accepted as meeting the EI specification, it must be tested to the specification with an official witness designated by the EI committee present. This witness ensures that all procedures are followed per specification and that all test results meet the specification requirements. EI then issues a qualification approval for the:
 - Elements
 - Housing
 - Flowrate
 - Fuel Category

* EI Specification 1581, Sixth Edition, “Specifications and Qualification Procedures for Aviation Jet Fuel Filter/Separators”, December 2016.

** EI Specification 1582, “Specifications for Similarity For EI 1581 Aviation Jet Fuel Filter/Separators”, December 2011

EI SPEC 1581

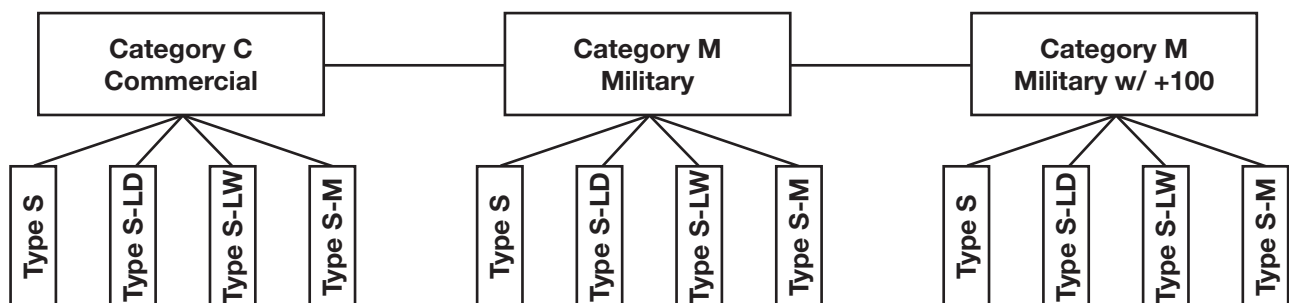

**FILTER/SEPARATOR SPECIFICATIONS
MAJOR MECHANICAL, TEST, & PERFORMANCE REQUIREMENTS**

Criteria		Specification Requirement
Test Fuel Additives	Category C	1.0 mg/l STADIS 450 + 15.0 mg/l DCI-4A
	Category M	2.0 mg/l STADIS 450 + 15 mg/l DCI-4A + 0.15% DI-EGME
	Category M100	2.0 mg/l STADIS 450 + 15 mg/l DCI-4A + 0.15% DI-EGME + 256 mg/l SPEC AID 8Q462
Test Series To Be Run		Single element
		Full scale
Fuel Handling	Single Element	Single pass from 1 tank to another
	Full Scale	Recirculate
Fuel Temperature	Minimum Temperature	40°F
	Maximum Temperature	90°F
	Deviation From Test Start Temperature	+/- 11°F
Maximum Clean Initial Differential Pressure		6 psid across filter/coalescer stage, 10 psid across vessel
Structural Strength Of Filter/Coalescer Element		75 psid with no rupture, bypassing of seals, or pinhole leaks
Structural Integrity Of Filter/Coalescer Element		No media or structural deterioration such as leaks or tears
Maximum Effluent Contaminant Levels During Tests	Fiber Content	10 fibers per liter
	Solids Content	1.0 milligram per gallon
	Free Water Content	15 parts per million
Conditioning Run Test	Flow Rate	3 gpm for single element test, 10% of rated flow for full scale test
	Test Duration	30 minutes
Water Coalescence Test - Clean Element	Flow Rate	Rated flow
	Test Duration	30 minutes
	Water Injection Rate	0.01% By volume
Solids Holding Test	Flow Rate	Rated flow
	Test Duration - Type S	75 minutes for single element, 45 min for full scale
	Test Duration - Type S-LD	Add solids until pressure reaches 22.5 psid, Then run additional 45 minutes with no addition
	Solids Injection Rate	72 mg/gal
	Maximum Delta P At 50 Minutes - Type S	15 psid
	Maximum Pressure At 75 Minutes - Type S	45 psid
Water Coalescence Test - Dirty Element	Flow Rate	Rated flow
	Test Duration - Single Element	1st period: 150 minutes, 2nd period: 30 minutes
	- Full Scale	1st period: 90 minutes, 2nd period: 15 minutes
	Water Injection Rate	1st period: 0.01%, 2nd period: 3.0% (0.5% For S-LW)
Vertical Vessel Length To Diameter Ratio	Vessel ≤ 24 Inches	1.75
	Vessel > 24 Inches	2.5
Minimum Spacing Between Elements And Between Element & Vessel Wall		0.5 inches

Similarity Certification Form

(See form VEL1739 on our website or print out this form and send to contact info below)

Email: velconquotes@parker.com
Fax No.: 719-531-5690
To: Parker AFD
1210 Garden of the Gods Road
Colorado Springs, CO 80907-3410
Attn: Aviation Products Manager

Date: _____
From: _____
Company: _____
Address: _____

Phone: _____
Email: _____

Please recommend coalescer cartridges, separators, monitor cartridges and conversion hardware, if any, for the vessels listed below to qualify them to EI 1581 6th Edition, or EI Certificate as appropriate, to satisfy requirements of ATA 103 and JIG.

1 Vessel Model No. _____ Max Flow Rate _____ USGPM
Serial No. _____ Unit No. _____ Cover Gasket No. _____
Presently Installed: Qty _____ Model No. _____ Coalescer Cartridges
Qty _____ Model No. _____ Separator Cartridges
Qty _____ Model No. _____ Monitor Cartridges
 Fixed Mobile
EI 1581 6th Edition: Category C Category M Category M100
Certificate: EI 1583 Certificate

2 Vessel Model No. _____ Max Flow Rate _____ USGPM
Serial No. _____ Unit No. _____ Cover Gasket No. _____
Presently Installed: Qty _____ Model No. _____ Coalescer Cartridges
Qty _____ Model No. _____ Separator Cartridges
Qty _____ Model No. _____ Monitor Cartridges
 Fixed Mobile
EI 1581 6th Edition: Category C Category M Category M100
Certificate: EI 1583 Certificate

3 Vessel Model No. _____ Max Flow Rate _____ USGPM
Serial No. _____ Unit No. _____ Cover Gasket No. _____
Presently Installed: Qty _____ Model No. _____ Coalescer Cartridges
Qty _____ Model No. _____ Separator Cartridges
Qty _____ Model No. _____ Monitor Cartridges
 Fixed Mobile
EI 1581 6th Edition: Category C Category M Category M100
Certificate: EI 1583 Certificate

EXAMPLE (For EI1581 6th Edition Conversion)

Vessel Model No. HV-2933M150 Max Flow Rate 755 USGPM
Serial No. SO54321 Unit No. Truck #127 Cover Gasket No. G-0769
Presently Installed: Qty 7 Model No. I-633C5TB Coalescer Cartridges
Qty 2 Model No. SO-636V Separator Cartridges
Qty _____ Model No. _____ Monitor Cartridges
 Fixed Mobile
EI 1581 6th Edition: Category C Category M Category M100
Certificate: EI 1583 Certificate

SO-6xxG Separator Assembly Installation Instructions

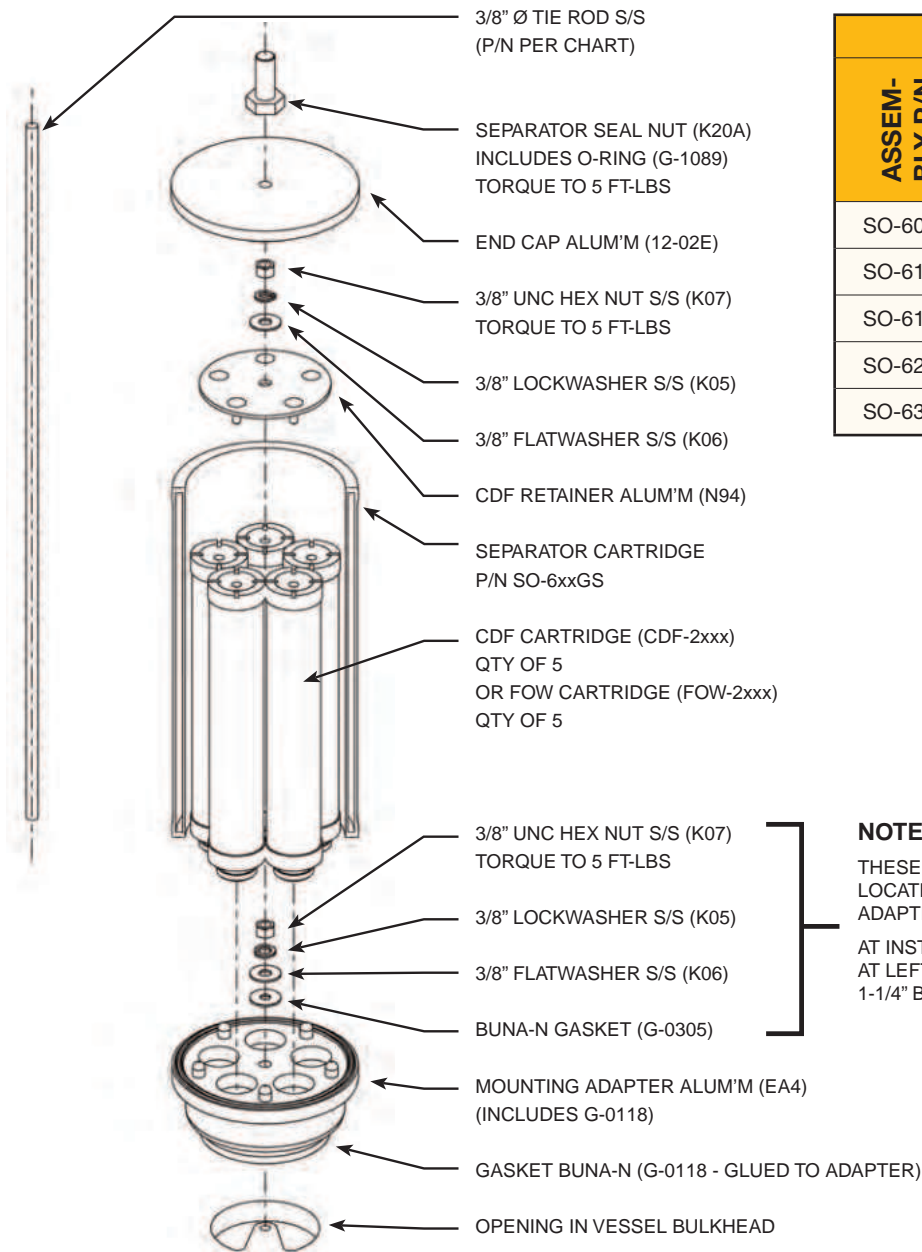

TIE ROD DATA		
ASSEMBLY P/N	TIE ROD P/N	LENGTH (IN.)
SO-606G	T11.0-6D	11
SO-613G	T18.0-6D	18
SO-616G	T21.0-6D	21
SO-623G	T28.0-6D	28
SO-633G	T38.0-6D	38

NOTE:

THESE NUTS AND WASHERS ARE LOCATED AT UNDERSIDE OF THE ADAPTER WHEN SHIPPED.

AT INSTALLATION, RELOCATE AS SHOWN AT LEFT WITH TIE ROD PROTRUDING 1-1/4" BELOW BASE OF ADAPTER.

Maintenance Instructions

PTFE Coated Screen Separator Cartridges

DO NOT THROW PTFE COATED SCREEN SEPARATOR CARTRIDGES AWAY WHEN CHANGING COALESCERS. These separators are designed to eliminate the costly practice of replacing paper separators. It is recommended, however, that the separators be inspected, tested and cleaned at every coalescer change to assure prolonged, effective separation life. The procedure for this is described below:

1. Throughout the entire procedure, **AVOID LETTING SCREEN COME IN CONTACT WITH YOUR BARE SKIN**, particularly after the cartridge has been cleaned. Hold the cartridge by the end-caps. If necessary to handle the screen during

removal or installation, use a clean, dry, non-abrasive material, such as a poly-bag from one of the coalescers, between your hand and the screen.



2. After removing the cartridge from the vessel, submerge it in clean fuel and gently scrub the entire screen surface with a soft bristle brush or a lint free cloth.



3. **SURFACE INSPECTION.** Holding the cartridge by the endcaps, visually inspect the entire surface of the screen for any nicks or cuts. If there are any visible flaws, they should be patched (see Step 6).



4. **WATER TEST.** Be sure that the separator is fuel-wetted before performing this test. Hold the cartridge by the end-cap at an angle, and gradually pour water over the entire screen surface. Do not spray the water and do not let it fall more than a distance of three inches before contacting the screen.

5. The water will bead and roll off the surface of properly functioning separators (as it would on a freshly-waxed car). If this is the case, the separator has passed the Water Test and can be reused.



6. If any portion of the PTFE coated screen is wetted by the water (the water will seep into the pores of the screen; this is very obvious to the eye), the cartridge has failed the Water Test. The wetted area must be cleaned again (see Step 7), and the recleaned cartridge should pass the Water Test before it is reinstalled.

NOTE: The separator in the photo above has been purposely disarmed to show a water-wetted surface.

RIGHT WAY

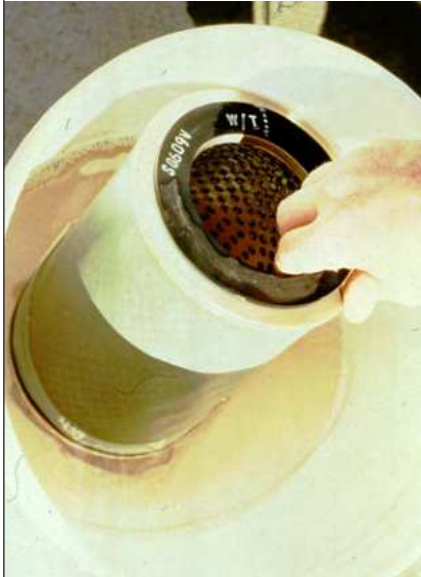

Handle Cartridge Carefully Do Not Touch the PTFE Sides!

WRONG WAY



7. If the separator passes the Surface Inspection and Water Test, rinse it thoroughly in clean fuel to remove traces of water. Let the separators air dry prior to reinstalling.
8. If a separator fails the Surface Inspection due to visible nicks, cuts, or other flaws in the screen that can be caused by mishandling, they can be patched if they are smaller than $\frac{1}{8}$ inch (size of dot ●). Use two-part epoxy base putty. Thoroughly clean area with isopropyl alcohol before applying putty.
9. If a separator fails the Water Test due to visible wetted areas, try washing the cartridge with hot water. Use pressurized hot water from a tap or hose and thoroughly spray the wetted area. Scrubbing with a soft brush will often help on stubborn areas. Allow the cartridge to dry, then perform the Water Test again. If the cartridge continues to fail the Water Test, it must be replaced.

ALWAYS REPEAT THE WATER TEST TO INSURE A GOOD PATCH.

BE SURE THAT THE SEPARATOR IS FUEL-WETTED BEFORE PERFORMING THIS TEST.

10. If gaskets should become dislodged, thoroughly clean gasket and end-cap surfaces with a solvent such as MEK or Acetone. Apply a cyanoacrylate adhesive, such as Bostik #7432, to end-cap. Place gasket onto end-cap, applying pressure over entire surface of gasket. Let dry approximately 30 seconds.
11. REMINDER. While reinstalling the PTFE coated screen separators, be sure to avoid handling the screen with your bare hands. If you must handle the screen, use a clean, dry, non-abrasive material, such as a poly-bag. Be sure to remove all poly-bags prior to closing vessel.

NOTE: The above cleaning instructions are also applicable to the Parker Velcon synthetic media separators. These can be cleaned a maximum of two times before they should be replaced.

Cartridge Changeout Curve

Coalescer and Monitor Cartridge Changeout Curve For Cartridges at Reduced Flow Rates

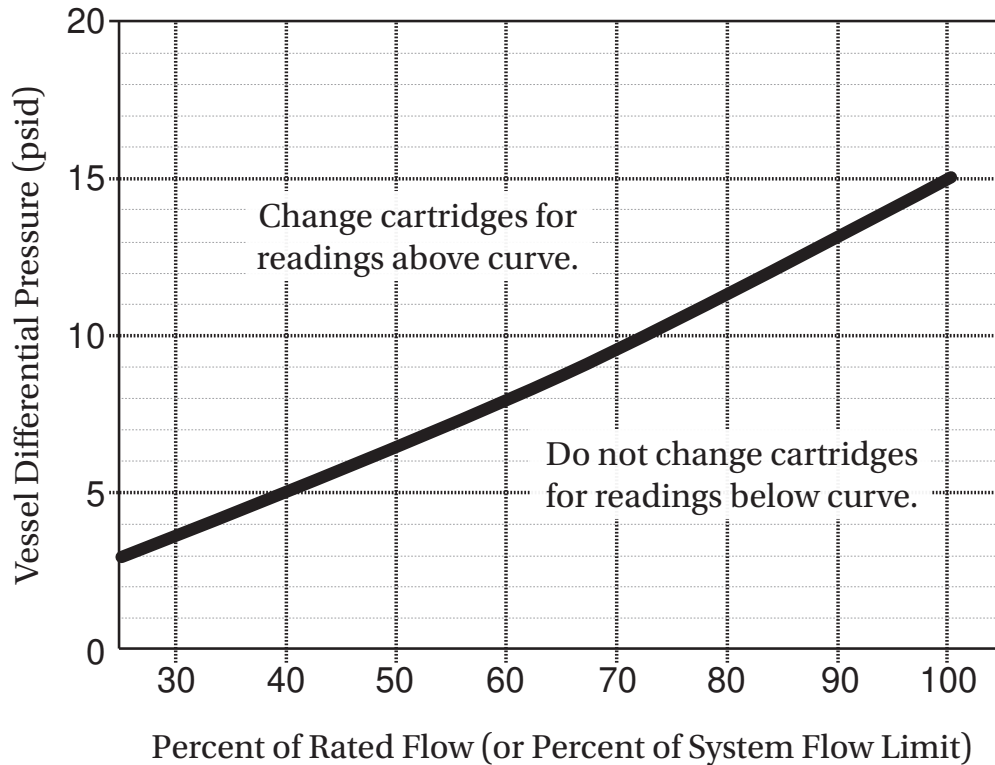

Parker AFD recommends changing coalescer and monitor cartridges when the pressure differential reaches 15 PSID and the filter/separator is being operated at its rated flow. The system, however, will often be operating at lower flow rates with a corresponding lower differential pressure. If, for example, a 600 GPM filter/separator shows a differential of 12 PSID at 300 GPM and the flow rate was increased to 600 GPM, the differential would be about 28 PSID which is considerably above the recommended pressure drop for changing cartridges.

It is important, therefore, to know the pressure differential characteristics at lower flow rates for a set of coalescer cartridges which are plugged to the extent

that they would show a 15 PSID differential at rated flow. The graph below contains this information for Parker Velcon cartridges.

Vessel pressure drop characteristics for coalescer and monitor cartridges complying with ATA Specification 103.

EXAMPLES:

A 1000 GPM filter/separator is operating at 600 GPM (60% of rated flow). If the pressure differential is less than 8 PSID, the cartridges do not require changing. If the pressure differential is 8 PSID or more, however, the elements are due for a changeout.

EXCEPTION:

If the system in this example is limited to a maximum flow of 750 GPM by pump capacity or some other factor, then 750 GPM should be considered 100% of rated flow rather than higher rating of the filter/separator. In this case, the 600 GPM flow would be 80% of rated flow and the differential at this rate can be as high as 11 1/2 PSID without changing elements.

NOTE:

"Stick-on" labels (Form VEL1979) of the above graph can be obtained from Parker Velcon, Colorado Springs. These labels can be affixed to the vessel near the differential pressure gauge.

Notes

Mission

Parker AFD is committed to being the world's preferred source for the expert aviation filtration solutions we deliver to our customers.

Values

Superior customer service

Profitable growth

Meet or exceed customer expectations

Accountability

Integrity

